

SHOPRIDER NEW ZEALAND

MOBILITY SCOOTER USER'S GUIDE



CONTENTS

	page		page
1 Introduction.....	1	5.2 Mounting.....	6
2 Features.....	1	5.3 Basic Driving.....	6
3 Safety Precautions.....	2	5.3.1 Steering.....	6
4 Adjustments.....	3	5.3.2 Reversing.....	6
4.1 Seat Slide Adjustment.....	3	5.4 Dismounting.....	6
4.2 Seat Swivel Adjustment.....	3	6 General Advice.....	6
4.3 Seat Height Adjustment.....	3	6.1 Control through Obstacles.....	6
4.4 Seat Tension Adjustment.....	3	6.1.1 Control through Doors.....	6
4.5 Captains Seat Back Angle Adjustment... 3		6.1.2 Control on Ramps.....	7
4.6 Armrest Width Adjustment.....	3	6.1.3 Control over Grass, Gravel and Hills..	7
4.7 Armrest Angle Adjustment.....	4	6.2 Parking in Public.....	7
4.8 Armrest Pad Length Adjustment.....	4	7 Maintenance.....	7
4.9 Armrest Height Adjustment.....	4	7.1 Wheels and Tyres.....	7
4.10 Tiller Angle Adjustment.....	4	7.1.1 Changing Wheels and Tyres.....	7
5 Scooter Operation.....	4	7.1.2 Tyre Pressure.....	7
5.1 Controls.....	4	7.2 Lubrication.....	8
5.1.1 Speed Adjustment Dial.....	4	8 Batteries and Battery Charging.....	8
5.1.2 Horn.....	4	8.1 Batteries.....	8
5.1.3 Thumb Lever Control (Wig Wag).....	4	8.2 Battery Charging.....	8
5.1.4 LED Battery Indicator.....	5	9 Troubleshooting.....	9
5.1.5 Key Switch.....	5	9.1 Circuit Breaker and Fuse.....	9
5.1.6 Charging Socket.....	5	9.2 If the Scooter does not run.....	9
5.1.7 Lights.....	5	10 Warranty Information.....	9
5.1.8 Hazard Lights.....	5		
5.1.9 Indicators.....	5		
5.1.10 High/Low Speed Switch.....	5		
5.1.11 Free Wheeling Device.....	5		
5.1.12 Anti Tip Wheels.....	5		

1. INTRODUCTION

Congratulations on your purchase of the Shoprider Scooter. This scooter is the ultimate combination of style and comfort and incorporates Shopriders latest innovative designs. Your scooter has been designed to be easily manoeuvred within the smallest spaces both in and outdoors. Direct drive rear wheels and electromechanical disk brakes provide a safe comfortable ride. This Shoprider scooter is designed for persons with limited mobility.

This manual contains important information regarding the safe use of your scooter. Please, read it carefully before using the scooter and make sure you understand the instructions.

2. FEATURES



- | | |
|---|---|
| 1 Tiller control head | 8 Adjustable angle fold down detachable seat |
| 2 Head light | 9 Foot rest |
| 3 Rear reflectors | 10 Tiller steering column and steering wheel angle adjustment |
| 4 Side reflectors | 11 Front bumper |
| 5 Adjustable width, length and angle armrests | 12 Detachable basket |
| 6 Swivel seat | 13 Battery charging plug (left or right side) |
| 7 Seat height adjustment | |

3. SAFETY PRECAUTIONS

- Do not drink alcohol and drive
- Do not drink/eat or use a mobile phone while riding
- Do not carry passengers
- Do not exceed any incline over 9°
- Do not turn on steep inclines
- Do not proceed on any incline that has oil, ice or other slippery substances
- Proceed carefully when on any incline, always lean forward
- Do not operate scooter without anti-tip wheels attached - doing so could cause injury
- Do not turn suddenly at full speed
- Do not mount or dismount the scooter unless the brake is engaged and the key is off
- Do not switch off the scooter while the scooter is moving
- Do not ride the scooter where you cannot safely walk (e.g. soft dirt/sand, deep grass, loose gravel)
- Always proceed carefully while riding on uneven surfaces
- Do not ride the scooter on roads, streets or motorways
- Remember to observe all rules and regulations of other pedestrians
- Do not attempt to climb over kerbs greater than 2 inches (5cm). For kerbs under 2 inches, always approach slowly and at 90° to the kerb.
- Do not reverse the scooter unless the speed dial is set low
- Always stop fully before changing direction (forward or reverse)
- Always keep your feet on the platform when riding
- Do not use parts or accessories that are not authorised by Shoprider NZ
- Do not connect any medical device to the scooter battery - doing so could cause injury
- Do not exceed the suggested user weight limit - doing so could cause injury and invalidate the warranty
- Make sure the tiller and seat are properly adjusted - failure to do so could cause personal injury
- Do not sit on your scooter while the scooter is being transported in a vehicle - doing so could cause injury
- Do not use the scooter as a commercial delivery vehicle, e.g. for delivery of leaflet, newspapers etc
- Do not use the scooter in the rain, in the shower, or in any wet environment - direct exposure to wet can cause rust and failure of the electronics

Shoprider/Shoprider NZ Ltd are not responsible for any damage or injury caused due to improper or unsafe use of their scooters.

EMI Warning

Shoprider scooters may be susceptible to electromagnetic interference (EMI), which is a kind of interfering electromagnetic energy (EM) emitted from sources such as radio stations, TV stations, amateur radio (HAM) transmitters, two-way radio, and cellular phones. Do not operate hand held transceivers (transmitters-receivers), such as citizens band (CB) radios, or turn on personal communication devices, such as cellular phones, while the scooter is turned on. Be aware of nearby transmitters, such as radio or TV stations and try to avoid getting close to them. Adding accessories or components or modifying the scooter may make it more susceptible to EMI.

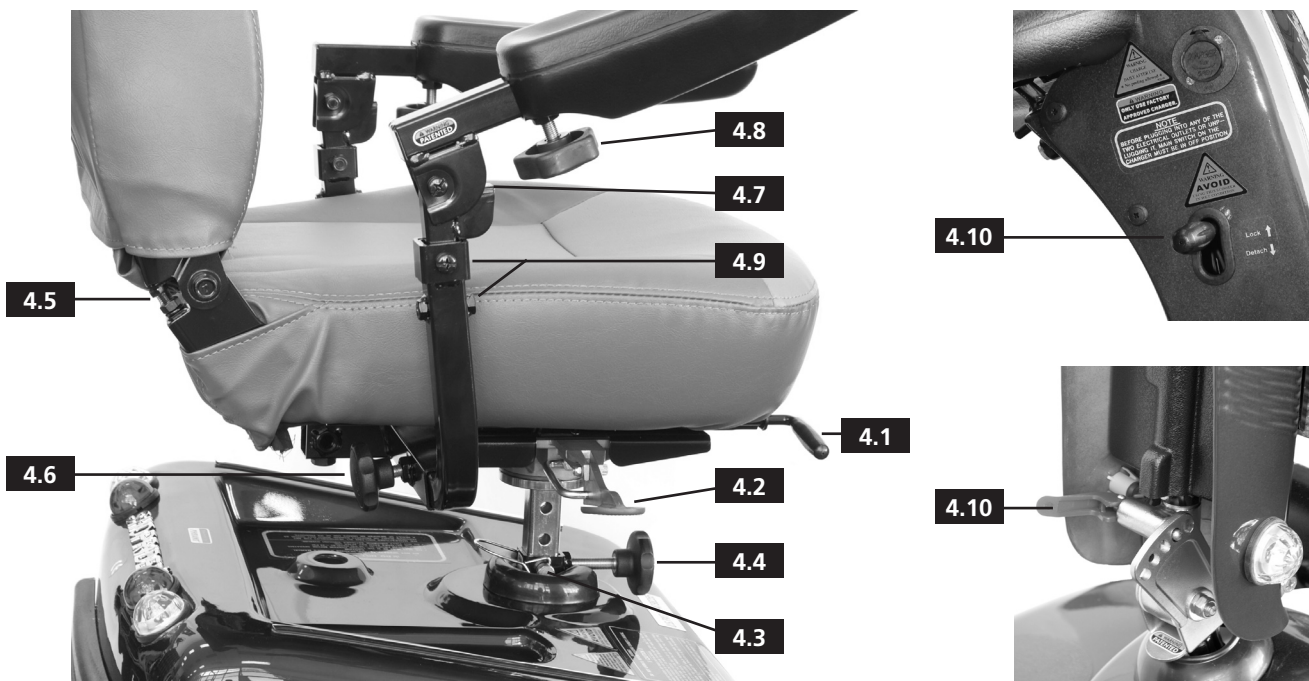

4. Adjustments

4. ADJUSTMENTS

The Shoprider Scooter allows various adjustments to be made to suit the individuals requirements:

4.1 - SEAT SLIDE ADJUSTMENT

A lever located on the side of the seat, allows you to adjust your seat forward and back. Simply lift the lever and move in the desired direction. As soon as you release the lever, the seat will lock in the new position you have selected.

4.2 - SEAT SWIVEL ADJUSTMENT

Lift lever and rotate the seat around, releasing the handle when finished. The seat will lock into one of four positions on the seat mounting plate.

4.3 - SEAT HEIGHT ADJUSTMENT

Located on the main frame, the tube receiving the seat has four height adjustment holes. By the fitting of a steel pin supplied in any one of the holes, 4 heights can be achieved.

4.4 - SEAT TENSION ADJUSTMENT

The seat tension hand knob tightens on the main stem and takes out any possible side play, ensuring that maximum stability is given.

4.5 - CAPTAIN SEAT BACK ANGLE ADJUSTMENT

The backrest has on each side of its base an adjustment screw and lock-nut. These can be set to give the required angle up to a maximum of 12°. The back is also provided with an adjustable head rest extension. The back folds down on to the seat allowing the unit to be stored in a limited space.

4.6 - ARMREST WIDTH ADJUSTMENT

On each side underneath you will find a knob. By loosening this knob you are able to adjust the armrests to whatever width you desire. The armrests can be removed for transporting the scooter but must be fitted when using the scooter.

4.7 - ARMREST ANGLE ADJUSTMENT

Pull up on the end of the armrests and they will flip back up allowing easy transfer in and out of the seat. Under the armrests, on some models, there is a bolt and lock-nut that can be adjusted up/down to change the angle of the armrests.

4.8 - ARMREST PAD LENGTH ADJUSTMENT

Located under each armrests is a hand knob. By turning anti-clockwise to release, the armrest can be extended and reset in position by re-tightening the hand knob.

4.9 - ARMREST HEIGHT ADJUSTMENT

Below the rear of the armrest on the down supporting tube there is a screw and locknut that allow for adjustment. On some models two Allen screws prevent any loose play.

4.10 - TILLER ANGLE ADJUSTMENT

On the left side at the base of the tiller is a red release lever. Push the lever to adjust the tiller angle to one of the pre-set positions. Pull the lever back to lock in position. On the Shoprider TE 889XLSN, the release lever is situated on the right side near the top of the tiller. Push down on the lever to adjust the position and lift the lever to lock in place.

5. SCOOTER OPERATION

5.1 - CONTROLS

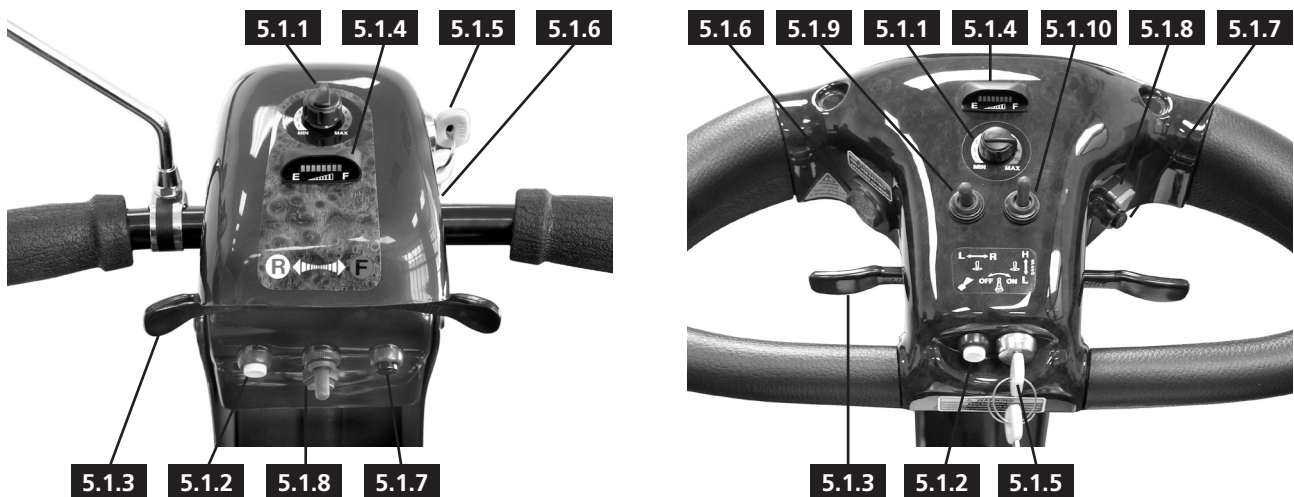

5.1 Controls

5.1.1 - Speed Adjustment Dial

This allows you to select your desired top speed. The dial can be set anywhere between the 0 (slowest) and 10 (fastest) speed setting.

5.1.2 - Horn Button

Press the yellow horn button to sound the horn.

5.1.3 - Thumb Lever Control (Wig Wag)

This controls your speed and forward and reverse motion. The right thumb lever moves the scooter forward and controls the speed. The left thumb lever moves the scooter in reverse and also controls the speed. When the lever is released you will stop gently and the electromagnetic brake will be applied.

5.1.4 - LED Battery Indicator

These indicate the amount of charge you have in the batteries. The number of bars lit, shows the amount of charge left in your batteries. The amount of charge will only show at its true level when the scooter is in drive.

WARNING! - Do not allow the bars to go out completely as the complete discharge of the batteries could cause them irreversible damage.

5.1.5 - Key Switch

Insert the key and turn clockwise(the LED bars will illuminate). There is a 3 second delay while the controller checks its circuits before the thumb lever control can be operated. Turn key anti-clockwise to turn scooter off.

5.1.6 - Charging Socket

Located on either Left or Right (models vary) side you will find the charging socket. For recharging the batteries see 8.2 for battery charging.

5.1.7- Lights

Press the blue button to turn the light(s) on and press again to turn off.

5.1.8 - Hazard Lights

Press the red button shaped like a triangle for the front and rear hazard lights to operate

5.1.9 - Indicators (on deluxe models)

A black switch works the indicators left or right when moved sideways.

5.1.10 - High/Low Speed (on deluxe models)

This black switch offers a low speed or high speed range with a flick of the switch.



5.1 Controls

5.1.11 - Free Wheeling Device

Located on either left or right side of the scooter depending on the model number of the scooter (easy to locate as it has a red handle lever). To freewheel the scooter push down the lever. To engage the motor again, simply pull the lever up. In freewheel mode the speed control will not move the scooter and the scooter will not operate.

WARNING! - Always re-engage the free wheeling device after use. Failure to do so may result in injury. Do not sit on the scooter while in freewheel mode.

5.1.12 - Anti-Tip Wheels

These wheels are located on the rear frame of the scooter.

5.2 - MOUNTING

For your first sessions, be sure that you and the scooter are on a level surface. Put the key in its slot, but leave it turned off. Grip the hand lever located at the right hand side of the seat and pull the lever up. This will release the seat from its set location. The seat has four fixing points and when rotating the seat after release from one of its locations the spring-loaded catch will lock into your required position. Seat yourself and swing the seat to face the handlebars. Make sure you are straight.

5.3 - BASIC DRIVING

- 1 Make sure you are properly seated on the scooter
- 2 Turn the Speed Adjustment Dial (fig 5.1.1) to slow.
- 3 Turn key (fig 5.1.5) to the ON position.
- 4 Press the right thumb control (fig 5.1.3) to start in a forward motion. You will very gently accelerate.
- 5 Releasing the lever will automatically apply the brake and you will gently stop. Practice these basic functions until you get used to them.

5.3.1 - Steering

Steering the scooter is easy and natural. Just be sure to remember to give wide clearance when turning so that the rear wheels clear any obstacle. If you must steer in a tight spot, such as entering a doorway or when turning around, stop, turn the handlebars to where you want to go, then apply power gently. This will make the scooter turn very sharply, but it will still go gently and with complete stability.

5.3.2 - Reversing

Reversing the scooter requires greater attention. Turn your Speed Adjustment Dial to slow before you reverse (fig 5.1.1). Push the left Thumb Lever Control. Remember to turn your steering column before applying power. Steer wide of all corners and obstacles.

5.4 - DISMOUNTING

Before dismounting, ALWAYS turn key to the OFF position.

- 1 Locate the seat lever and pull the lever up.
- 2 Swing the seat away ensuring it locks into position, and ease onto your feet.

CAUTION! - *If you require steadying when mounting or dismounting the scooter, use the armrests rather than the front tiller*

6. GENERAL ADVICE

6.1 - CONTROL THROUGH OBSTACLES

The chances are that when you start really using your scooter you will meet some obstacles that will require some practice to drive through smoothly. Here are some common obstacles, with tips that will help master them quickly. You will soon be in control through heavy doors, up and down ramps, up and over kerbs, through grass, gravel and up hills with surprising ease by following these tips.

6.1.1 - Control Through Doors

Approach the door slowly. If the door opens away from you, hold the doorknob or bar in one hand and apply the power with the other hand. If it is a self closing door, you can go through allowing the door to close behind you. If not, just stop when you are clear of the

door and push it closed. If the door opens towards you, hold the knob or bar with one hand and gently press on your left thumb lever, and allow the gentle reverse power to do the work. When the door is open wide enough, push the forward lever and go ahead quickly, leaving your hand on the door to keep it free of the scooter and letting go as you pass the doorjamb.

6.1.2 - Control on Ramps

Many public buildings have ramps for scooters access. Some have a turn in the middle, and good cornering is required. Having stopped while facing uphill, starting up again simply requires that you apply forward power.

Going down any ramp or hill, keep the speed adjustment dial set to "Slow". This will keep you in a safely controlled descent. If you wish to stop completely, simply release the thumb control lever.

6.1.3 - Control Over Grass, Gravel and Hills

The Shoprider scooter performs admirably in grass, gravel and on hills. However, you must not exceed the guidelines set down in this guide. Please, refer to the safety precautions (page 2). Safety must always come first. If you are unsure about any situation, avoid it. Feel free to use your scooter on lawns or in park areas. Packed gravel such as on drive-ways or roads will present no problem. Avoid long grass, loose deep gravel as well as loosely packed sand. Because of the power of your scooter, you are able to climb steep hills, but the maximum safe grade limit is 9° - the reason for this is to ensure proper stability. Try to avoid wet weather and wet surfaces, rain or showers may cause electrical faults and wet surfaces can become slippery.

6.2 - PARKING IN PUBLIC

If you need to park and leave the scooter, simply remove your key. This will keep the brake on and will make your scooter difficult to move. It is best to leave it in sight of someone like a shop assistant who can watch it for you.

7. MAINTENANCE

7.1 - WHEELS AND TYRES

All Shoprider Scooters have split rim wheels. This allows any puncture to be repaired with ease.

7.1.1 - Changing Wheels and Tyres

When changing a wheel, remove the centre bolt and then remove the wheel. Replace with new/repaired wheel and re-bolt the centre bolt to the hub. When changing a tyre you must deflate the tyre. Remove the centre bolt and the four lock nut bolts after deflation to split the wheel.

7.1.2 - Tyre Pressure

The recommended tyre pressures are Front 25 psi and Rear 30 psi. The tyre pressure must not exceed 50 psi (psi = pounds per square inch). Tyre pressures should be checked regularly.

CAUTION! - On the tyre itself it states that maximum tyre pressure is 50 psi. Please, note that this is the maximum tyre pressure and the tyres should never be inflated to this pressure.

7.2 - LUBRICATION

At six month intervals you should lubricate the following parts with a light oil or similar lubricant:

- Seat pivot post
- Seat release lever pinion
- Wheel bearings
- Axle of scooter

CAUTION - Do not use WD40 to lubricate parts!! Do not lubricate transaxle/gear box!! In the event of any difficulties please consult your provider.

8. BATTERIES AND BATTERY CHARGING

8.1 - BATTERIES

The Shoprider Scooters are supplied with two sealed lead acid or gel maintenance free batteries. These are fitted under the seat in the centre of the scooter. For easy handling, Velcro carrying straps are provided to assist in fitting or removal. The range of the batteries can be affected by temperature, terrain, battery condition, weight of user, etc. The battery level indicator is only a guide and is most effective when the scooter is moving, only then is the true discharge level displayed.

- When the scooter stops the battery level indicator may indicate full
- An active user can use up to 30% of battery capacity or more per day
- Inactive users may only use 50% of battery capacity in a week
- In both these instances the battery should be put on charge over night

CAUTION! - Batteries should be kept fully charged at all times. They must not be left in a discharged state if not used for some time.

8.2 - BATTERY CHARGING

Charge the batteries completely (8 - 12 hours) prior to first time use.

The batteries supplied with your scooter are specially designed and require an automatic battery charger which is supplied with the scooter. All chargers are fitted with an electronic switch that terminates the charge when the batteries are fully charged.

To re-charge your scooter follow the procedure below:

- 1 Turn the key to the OFF position
- 2 Plug the charger into the wall socket making sure the switch is in the OFF position
- 3 Insert the battery charger interconnect, three prong metal plug into the interconnect socket on the right side of the tiller, at the top (fig 5.1.6)
- 4 Turn the power ON at the power outlet. The RED light on the battery charger will let you know the power is ON, the GREEN light will blink on and off to let you know the battery is now charging. When the battery is fully charged the GREEN light will stay on.
- 5 Everytime you use the scooter you should always put it on charge overnight, leave it on charge overnight and turn the charger off in the morning. This will make sure that your batteries are 100% fully charged to get the best performance from your batteries.

CAUTION! - The charger is for indoor use only. Do not expose to rain or spray. Do not cover the battery charging vent. Always ensure that the charging lead is in good condition and has not been damaged or stretched.

9. TROUBLESHOOTING



9. Troubleshooting

9.1 - CIRCUIT BREAKER AND FUSE

Your scooter is fitted with controls that protect the electrical system from overloads. If your scooter stops for no reason, it may be due to the circuit breaker. The circuit breaker can be located through a hole on the top of the rear chassis cover. On rare occasions, there may be an overload. If this occurs, the circuit breaker will pop out. To reset, turn the key to the OFF position, press the circuit breaker button and then turn the key to the ON position.

9.2 - IF THE SCOOTER DOES NOT RUN

- Check the key is in the ON position.
- Check the circuit breaker.
- Check all plugs and connectors are firmly fixed.
- Make sure that the battery adapter is disconnected from the charger plug.
- Make sure that the freewheeling device is in the run position.
- Make sure that the batteries are fully charged

If the free wheel device has been operated with the scooter left switched on, then the scooter will not operate until the ignition key has been switched off then on again. If after checking these points your scooter is still not running, please contact your nearest authorised dealer.

10. WARRANTY INFORMATION

The Shoprider Scooter carries the following warranty against defects in materials

1. Chassis for a period of five years
2. All components of the unit for a period of 18 months excluding batteries, tyres, tubes and fuses
3. Batteries are covered by the battery manufacturers warranty.

Misuse of the scooter, operation not in accordance with the owners manual, exceeding the load capacity or performance specification and modifications to the scooter by anyone without approval by Shoprider NZ will void the warranty. Warranty only applies to the original purchaser.

Copy the following information from your dealer for future reference:

Model No. _____

*Serial No. _____

Charger Type & No. _____

Battery type & No. _____

Your Shoprider Dealer _____

*Serial number located on the rear chassis rail



SHOPRIDER[®]
New Zealand

Your Shoprider Dealer



By Hector Jones !