



C.T.M. MOBILITY SCOOTER

HS-928 Instruction Booklet



TABLE OF CONTENTS

INTRODUCTION	1
IMPORTANT PRECAUTIONS	2
ELECTROMAGNETIC INTERFERENCE AND WARNINGS	3
IDENTIFICATION OF PARTS	5
CHARGING THE BATTERIES	11
DISASSEMBLING YOUR SCOOTER	13
LCD DISPLAY PANEL	15
CAUTION	26
TECHNICAL SPECIFICATIONS	27

INTRODUCTION

Thank you and congratulations on purchasing your new C.T.M. Mobility Scooter. It is designed to provide you with transportation ability indoors and outdoors.

We pride ourselves on providing safe and comfortable products. Our goal is to ensure your complete satisfaction. We sincerely hope you enjoy your C.T.M. Mobility Scooter.

Please read and observe all warnings and instructions provided in owner's manual before you operate the various functions of this scooter. Also, please retain this booklet for future reference.

If you have any question, you can contact :

CHIEN TI ENTERPRISE CO., LTD.

No.13, Lane 227, Fu Ying Rd., Hsin Chuang, Taipei, Taiwan,

Tel : +886-2-2903-2987 Fax : +886-2-2903-8807

E-Mail : sales@chienti.com.tw http : //www.chienti.com.tw

or your local dealer:

IMPORTANT PRECAUTIONS

This scooter is designed for single person use only at any one time.

Maximum User Weight is 226 kg / 498 lbs

Turn key off before getting on or off.

Always drive carefully and be aware of others using the same area.

Always use pedestrian crossings wherever possible.
Take extreme care when crossing roads.

Do not drive on slope exceeding 9 degree, and take extreme care when turning on slope.

Do not use full power when turning.

A slow speed must always be used when ascending, descending or traversing a slope or incline and also on uneven terrain, ramps and soft or loose surfaces, such as gravel or grass.

Scooter may not operate well in high humidity.

Never put scooter in freewheel whilst on a slope.

Ensure you abide by any national traffic laws when using the scooter on paths and public highways.

To prevent any danger, when disassembling the tires, please release tires' pressure in advance (if using pneumatic tires).

Check tire pressure (if using pneumatic tires). Tire pressure remains at 2-2.4 bar (30~35 psi).

ELECTROMAGNETIC INTERFERENCE AND WARNINGS

CAUTION: It is very important that you read this information regarding the possible effects of Electromagnetic Interference on your motorized scooter.

Powered wheelchairs and motorized scooters may be susceptible to electromagnetic interference (EMI), which is interfering electromagnetic energy (EM) emitted from sources such as radio stations, TV stations, amateur radio (HAM) transmitters, two-way radios, and cellular phones. The interference (from radio wave sources) can cause the motorized scooter to release its brakes, move by itself, or move in unintended directions. It can also permanently damage the motorized scooter control system. The intensity of the interfering EM energy can be measured in volts per meter (V/m). Each motorized scooter can resist EMI up to a certain intensity. This is called its "immunity level." The higher the immunity level, the greater the protection. At this time, current technology is capable of achieving at least a 20 V/m immunity level, which would provide useful protection from the more common sources of radiated EMI. The immunity level of this motorized scooter model is not known.

There are a number of sources of relatively intense electromagnetic fields in the everyday environment. Some of these sources are obvious and easy to avoid. Others are not apparent and exposure is unavoidable. However, we believe that by following the warnings listed below, your risk to EMI will be minimized.

The sources of radiated EMI can be broadly classified into three types :

1. Hand-held portable transceivers (transmitters-receivers) with the antenna mounted directly on the transmitting unit. Examples include: citizens band (CB) radios, "walkie talkie," security, fire, and police transceivers, cellular telephones, and other personal communication devices



Some cellular telephones and similar devices transmit signals while they are ON, even when not being used

2. Medium-range mobile transceivers, such as those used in police cars, fire trucks, ambulances, and taxis. These usually have the antenna mounted on the outside of the vehicle; and
3. Long-range transmitters and transceivers such as commercial broadcast transmitters (radio and TV broadcast antenna towers) and amateur (HAM) radios



Other types of hand-held devices, such as cordless phones, laptop computers, AM/FM radios, TV sets, CD players, and cassette players, and small appliances, such as electric shavers and hair dryers, so far as we know, are not likely to cause EMI problems to your motorized scooter.

Motorized Scooter Electromagnetic Interference :

Because EM energy rapidly becomes more intense as one moves closer to the transmitting antenna (source), the EM fields from hand-held radio wave sources (transceivers) are of special concern. It is possible to unintentionally bring high levels of EM energy very close to the motorized scooter control system while using these devices. This can affect motorized scooter movement and braking. Therefore, the warnings listed below are recommended to prevent possible interference with the control system of the motorized scooter.

Warnings :

Electromagnetic interference (EMI) from sources such as radio and TV stations, amateur radio (HAM) transmitters, two-way radios, and cellular phones can affect motorized scooters. Following the warnings listed below should reduce the chance of unintended brake release or motorized scooter movement which could result in serious injury.

1. Do not operate hand-held transceivers (transmitters-receivers), such as citizens band (CB) radios, or turn ON personal communication devices, such as cellular phones, while the motorized scooter is turned ON;
2. Be aware of nearby transmitters, such as radio or TV stations, and try to avoid coming close to them;
3. If unintended movement or brake release occurs, turn the motorized scooter OFF as soon as it is safe;
4. Be aware that adding accessories or components, or modifying the motorized scooter, may make it more susceptible to EMI; and



There is no easy way to evaluate their effect on the overall immunity of the motorized scooter.

5. Report all incidents of unintended movement or brake release to the distributor listed on the inside front cover of this manual. Note whether there is a source of EMI nearby.

Important Information :

1. 20 volts per meter (V/m) is a generally achievable and useful immunity level against EMI (as of May 1994). The higher the level, the greater the protection.
2. The immunity level of this product is at least 20/Vm.

IDENTIFICATION OF PARTS

Before you take your first trip, you should familiarize yourself well with the operation of the scooter and with all operating elements. Take your time to test all functions and driving modes.



Figure 1 - HS-928 Front View

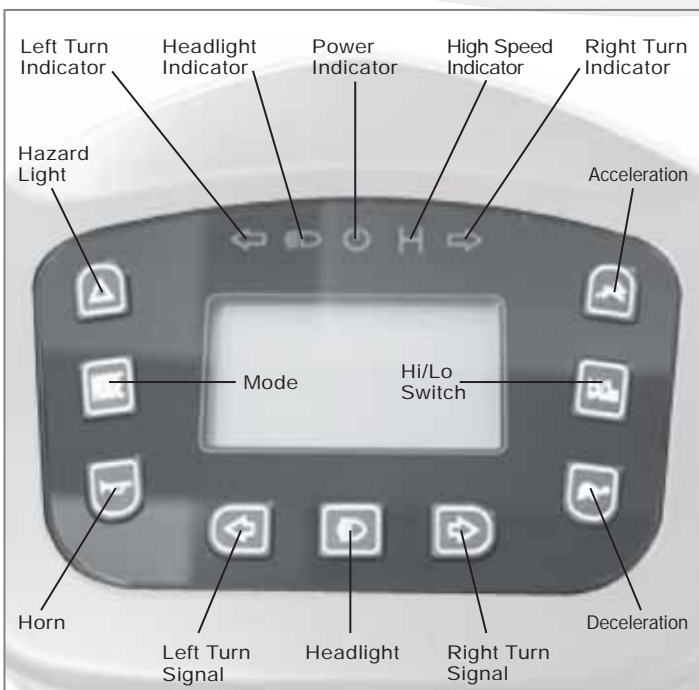

Figure 2 - HS-928 Control Panel



Figure 3 - HS-928 Rear View

FUNCTION OF PARTS :

Main Key Switch (A)

1. Turn the key to the right - Turn the scooter on
2. Turn the key to the left - Turn the scooter off



Always ensure that the scooter is switched off before getting on or off the scooter and before removing any items of the scooter



The ON/OFF key switch must only operated, when in motion, in an emergency. Turning the scooter OFF whilst driving will bring the scooter to an abrupt stop



Figure 4

TOP CONTROL PANEL

Hazard Light (B) : Switch on by pressing once, switch off by pressing again. Press hazard light button once, the right/left lights and parking indicator start to flash, warning tone acts as well; If the Hazard lights are activated, with the key switched to the on position, the lights will continue to flash even when the key is switched off. The Hazard light button should be depressed to cancel the flashing.

MODE (C) : Change mode by pressing once

- a. Clock
- b. Temperature
- c. Speedometer
- d. ODO
- e. Trip Meter

Horn (D) : Press horn button once to sound warning tone when necessary.

Left Turn Signal (E) : Press Left Turn Signal button once, the front and rear left turn indicators start to flash, and warning tone sounds simultaneously; press button again to switch off the turn indicators/signal and tone.

Right Turn Signal (G) : Press Right Turn Signal button once, the front and rear right turn indicators start to flash, and warning tone sounds simultaneously; press button again to switch off the turn indicators/signal and tone

Headlight (F) : Press headlight button once to switch on, switch off by pressing again.

Acceleration (H) : Press acceleration button once to increase speed, fine tune in 1'5 speeds.

Deceleration (J) : Press deceleration button once to decrease speed, fine tune in 1'5 speeds.

Hi/Lo Switch (I) : Press H/L Speed button once, the High/Low Speed Indicator will light on, means driving in high speed mode; Press again, the indicator will extinguish means driving in low speed mode.

(Hi/Lo speed will vary depend on your current speed settings)



Figure 5

Tiller Storage Compartment (K) Provide you a spacious room to put things.
 Hand Brake (L) Hold brake (L), when immediate stop is required.

 If you have to brake in an emergency, simply release the thumb lever, which will bring you to a halt!

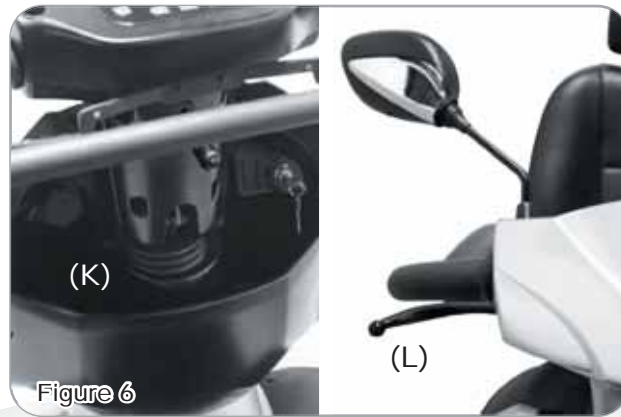

Wigwag Lever Operation

Pull the left-hand drive lever (M) carefully to travel forwards.

Pull the right-hand drive lever (N) carefully to travel in reverse.

(This can be reversed if required by local dealer.) Releasing both, engages automatic brake. These are also your accelerator. The further you depress them, the faster you go. (Subject to the position of the Rabbit / Turtle control).

 Keep LCD display panel and Wigwag Lever dry, if panel and Wigwag Lever get wet, allow to dry out before using.

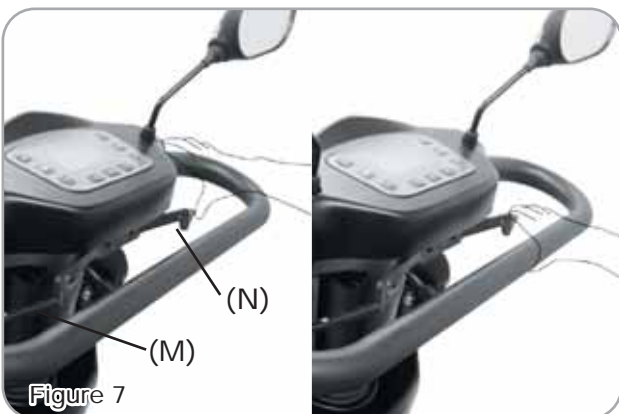

Steering Adjustment

By pressing regulator rod (N) down to adjust to any comfortable angles.

 Adjust regulator rod while driving is prohibited.
 Adjust steering to the foremost position before and after getting on the scooter.

Seat Fore-Aft Adjustment (P)

Pull the Seat fore-aft Adj Lever (Q) to disengage the seat (P). Slide the seat forwards or backwards into the required position. Let go of the lever (Q) again to lock the seat into its required position.

 When driving the scooter, set the seat (P) at foremost position to prevent tip over.

 Sit firmly on seat after getting on the scooter, do not stand on the foot rest to prevent tipping over or damaging to the scooter.

Angle Armrest Adjustment (R)

Pull the lever (S) and adjust the armrest to the required angle.

 Pull the armrest up when get on or off the scooter. Do not hang heavy parts on the armrests to cause tip over.

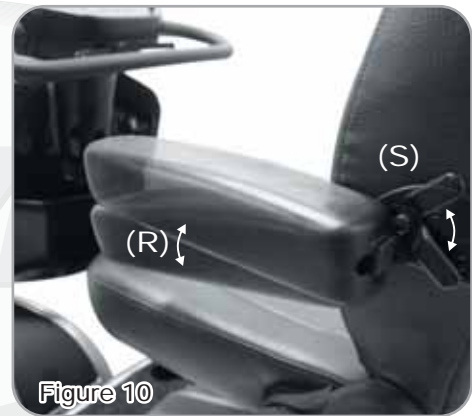

Seat Swivel Adjustment

Pull the lever (T) upwards to disengage and rotate seat (P) to required angle, Let go of the lever (T) to lock the seat into its required position.

Seat Back Angle Adjustment

Pull the lever (U) upwards to adjust backrest's angle, then release the lever when adjusted to required position.

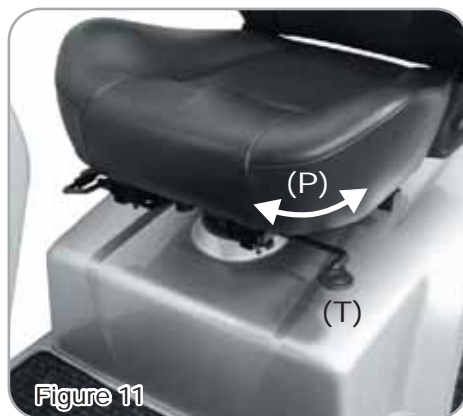



 For safety reasons the backrest's position must remain vertical before driving.

Seat (P) Height Adjustment

- 1.Refer to page 13 for disassembly, then remove seat (P) and rear shroud (Z). (Figs 18 & 19)
- 2.Remove screw, nut and washer from seat post (V). (Fig 13)
- 3.Adjust seat post (V) to desired height, and attached tightly with screw, nut and washers. (Fig 13)
- 4.Then assemble the rear shroud (Z), seat (P) back to its original position. (Fig 18 & 19)

Seat (P) Electrical Lifter (Optional)

- 1.Press seat lifter button  (W) lightly, seat will raise.
press  lightly, seat will lower.

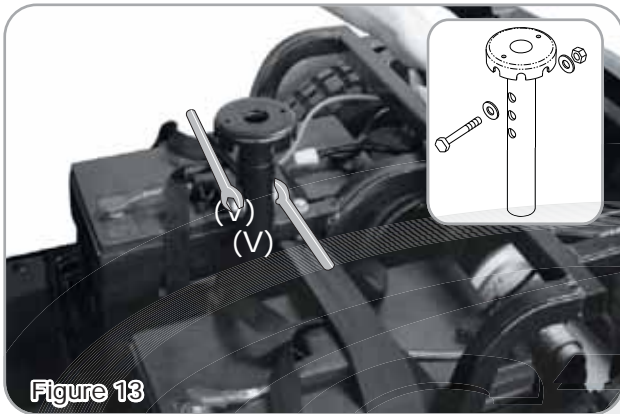

Figure 13

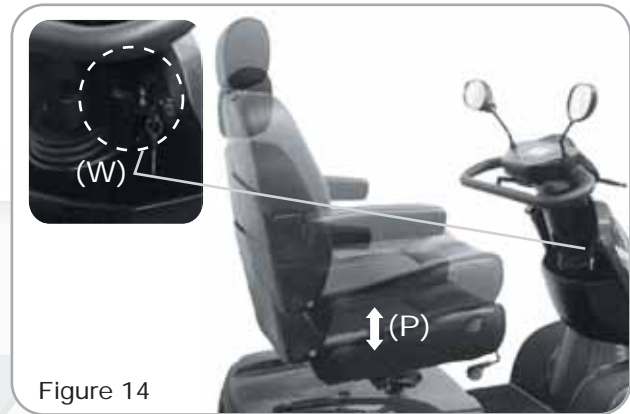

Figure 14



Do not operate this function on a slope, or in motion or under unstable condition.
The main purpose of this function is to assist you to reach certain height. Seat's position must remain at the lowest before driving.
Do not set N-D lever at N, before setting the seat at lowest position.
Please keep the center of gravity of the scooter in the middle, to prevent the scooter tipping over.

N-D Lever Adjustment :

- 1.When scooter stopped or malfunction, press the unlocking knob on the N-D lever (X). Push the N-D lever forwards this will allow you to push the scooter by hand.



Freewheel operation is only recommended on flat surfaces, never on gradients. Never leave your scooter on a gradient with its motors disengaged. Always re-engage the motors immediately after pushing the scooter.



The scooter won't operate, if the scooter is setting at N position, to restore to it's normal status, you must switch the power off and adjust to D position, then switch the power on.



Figure 15

Proportional Speed Reduction :

1. The scooter is equipped with proportional speed reduction. It will automatically reduce speed when encountering a corner, reducing speed corresponding to the angle of turn.
2. For safety reasons, when pushing the scooter by hand, if a pre-determined speed is exceeded, the controller automatically switches on and brakes the scooter.

 Avoid shifting your center of gravity as well as abrupt changes of direction when the scooter is in motion.

 Reduce speed before negotiating corners! Only accelerate when you have come out of the corner!

Tie - Down Hook :

To enable you to transport your scooter safely and securely there are 2 additional tie down hooks located on the underside of the scooter. (Fig 16)

 When fixed on a transportation system, N-D lever (**X**) must be located at D position. This scooter must not be occupied or used as a seat in a motor vehicle whilst being transported.

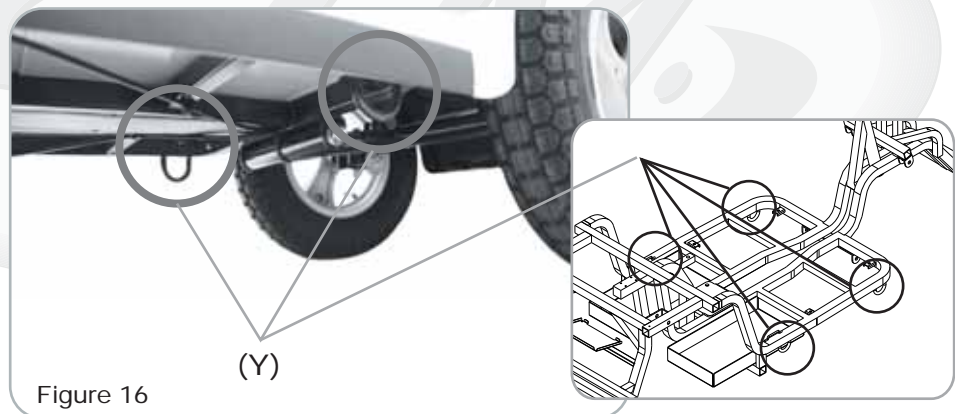

Figure 16

CHARGING THE BATTERIES

Batteries must be charged before using the scooter for the first time and should be recharged after each day use. You will need the scooter and the battery charger.



Each country may supply different charger. The charging procedure may be different from below. If you require more details, please contact your authorized dealer.

Be sure the scooter key is in the OFF position



Figure 17

Operation Steps :

Check if input voltage is right or not and make sure the grounding wire is OK.

Open the I/O switch, if the LED is on, the power supply has been connected too.

Connect to the power according to the requirement on the model list. If the LED is on, the power supply has been connected.

Connect input plug with battery correctly. LED is on and fan is working. Then CPU will carry on self-check and begin to charge.

Automatic shut down when battery is full.

LED indication :

#1 I/O : power switch (220vac/110vac).

#2 Thermal vent : insure good ventilation.

#3 Input : (power line according to safety requirement) - 220Vac or 110Vac.

1 LED : reference to labels on the body.

2 Output : materials of output (power line according to safely requirement)

O Output with relay wire.

N/O : The relay is in normal open situation when the charger is working; In this way, the scooter can not be operated during charge.

N/C : The relay is in normal close situation when the charger is working; In this way, the scooter can not be operated during charge.

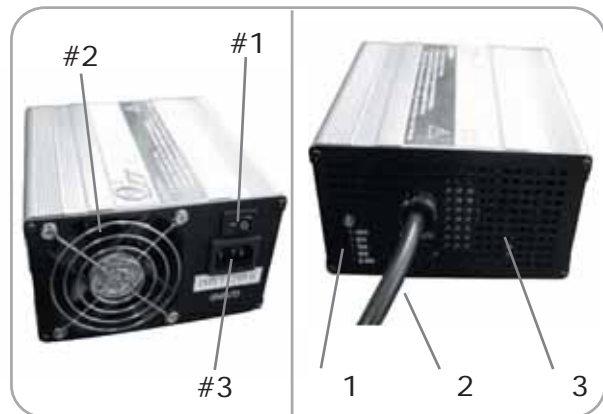

Maintenance & Repair must only be carried out by a Competent Engineer or Authorised Dealer or Agent.

3 Thermal vent : insure good ventilation.

Fault	Reason	Approach
Overheat and foam seriously	One battery cell has broken or badly sulphated	Check and replace the charger
Lack of power even we changed	Aging	Replace battery cells
	Output cables over 5 meters lead to much linear voltage drop.	Recover the input cable to the standard length of 2.5 meters
Battery doesn't charge any more after the first 10 minutes	Tripping due to high current when earth line is taken as zero line.	Link the zero line correctly
	Check the charger for overheating.	Ensure that the thermal vent is free from obstructions Check the fan to make sure it works naturally, please replace it if the fan doesn't work.
Power light is on, but battery doesn't charge any more	Connector is ok? polarity is right?	Link well first
	Battery is full?	Use first before charging
	Battery has broken	Replace battery
Power light is off	Power plug is attached properly?	Insert before charging
	Power switch is on?	Start before charging

 The time needed to recharge will vary depending on the depletion of the batteries. (Approx. 15 hours). Do no continuous charging for over 24 hours.

Warnings :

Fully charge batteries at least once a month, or more if you use scooter regularly. Charge after each trip exceeding 3 kilometers.

If storing your scooter for some time (1 month or more), make sure that batteries are fully charged, and on returning, charge them again before using scooter.

Batteries will only give maximum performance after scooter has been used, and batteries have been recharged up to 10 times. A bit like breaking in a new car.

DISASSEMBLING YOUR SCOOTER

Seat (P) disassembling :

Pull the lever (T) upwards to disengage the seat (P), hold the seat (P) firmly by the backrest and front edge and remove it upwards.



If found the seat (P) uneasy to remove, hold seat swivel lever (R), and then rotate the seat to reduce resistance then pull up.

Proceed with caution, if you need assistance, please have some one to help you

Rear Shroud (Z) and Batteries (C1) Disassembling :

- 1.Remove rear shroud (Z) upwards. (Figure 18)
- 2.Unplug two battery connectors (A1) (Figure 19)
- 3.Release Velcro (B1) (Figure 20)
- 4.Remove two batteries (C1) (Figure 21)



Take into account the heavy weight of the batteries (C1) please consider your physical condition before disassembling.

DO NOT short-circuit battery terminals (C1).

Battery's red wire plug connects to red positive location, black wire plug connects to black negative location.

For safety reason, please wash your hands after disassembly.

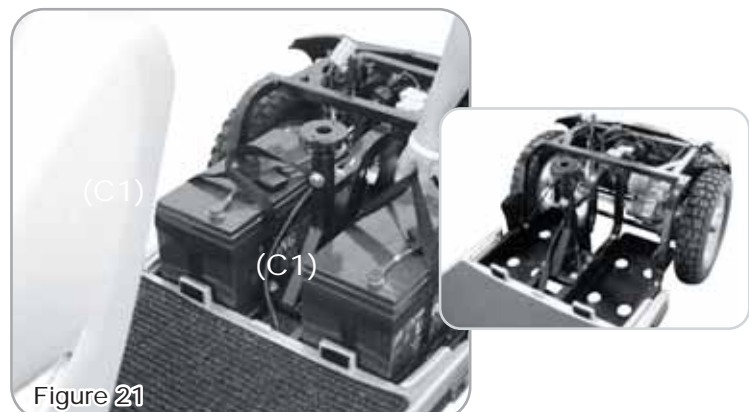
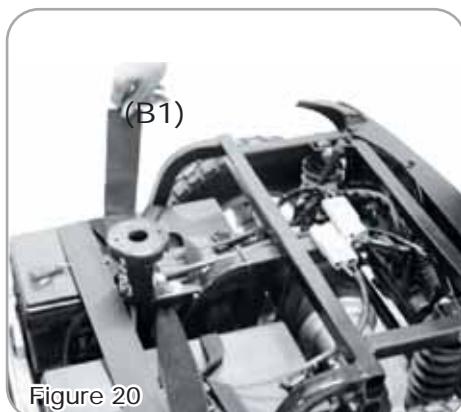
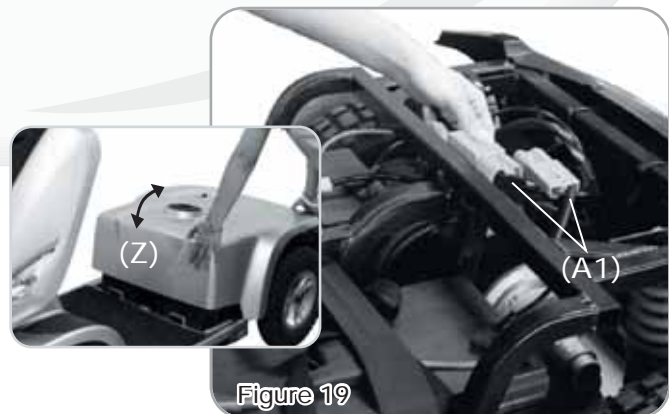

Fuse Replacement :

- 1.Remove rear shroud (Z), disconnect two batteries plug (A1). (Fig 22)
- 2.Open fuse box (D1), remove fuse (E1). (Fig 23 & 24)
- 3.Replace with backup fuse (F1), and close up the box. (Fig 24)



Replace with same power fuse is required.

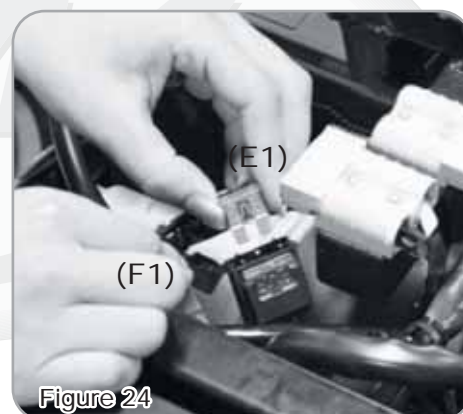
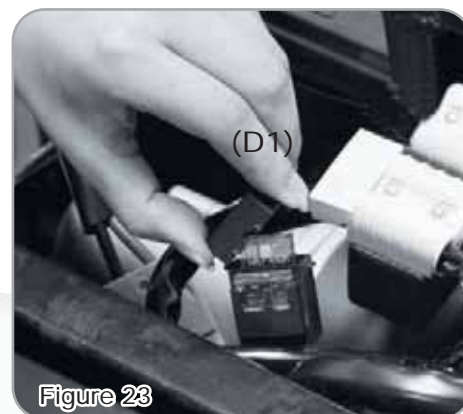
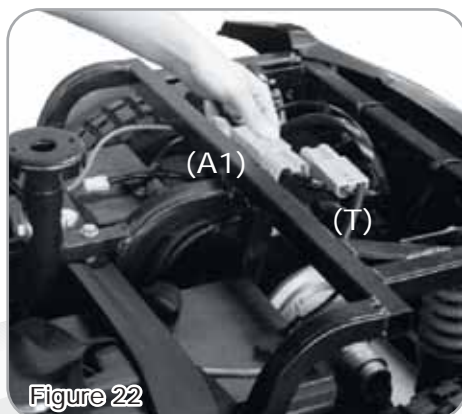

LCD DISPLAY PANEL



Figure 25

Function Buttons & Indicators

ITEM	SPECIFICATION
Control Buttons	Hazard Light, Horn, Right Turn Light, Headlight, Left Turn Light, Turtle(decelerate), H/L Speed, Rabbit(accelerate)
LED Indicators	Status Indicator (Green) Headlight Indicator (Green) Left / Right Indicators (Green) High/Low Speed Indicator (Green)
Connector	20PIN
LCD Back Light	Blue LEDs illuminate while key on.

Function Descriptions

FUNCTION	SPECIFICATION
1.Full Lighting Control	Headlight , Taillight, Left/Right Turn Signal, Hazard Light, Brake Light
2.Speedometer	7 Segment display (2 1/2 digits +1 decimal) "km/h" and "mph" symbol
3.Digital High / Low Speed Control	Low (L) Speed: 1 - 5 Rate High (H) Speed: 1 - 5 Rate
4.Power Indicator	Battery discharge and charging indicator (6 segments)
5.Malfunction Messages	Error code: 1~7 (1 digit) + LED Indicator
6.Key On Display	LCD full segments display
7.Warning Tone Setup	Volume adjustment for tones of Left/Right turn light, Parking light, Low voltage warning and horn

1.Full Lighting Control

Headlight, Taillight

ITEM	SPECIFICATION
Operation Feature	Take exterior headlight switch as determinant signal.
Control Mode	Press button to turn on headlight & turn signal and headlight indicator. Press button again to turn off headlight & turn signal and headlight indicator.
Usage Condition	While (1) controller shut down (2) on power-saving mode, all functions closed.
Remarks	(1) Loop Load of Headlight : 12V/50W Max (2) Loop Load of Taillight : 24V/50W Max (3) With "short circuit" and "overload" protection

Brake Light

ITEM	SPECIFICATION
Operation Feature	Take accelerator & manual brake as determinant signal.
Control Mode	While (1)accelerator is moved from Forward to Center position, (2)accelerator is moved from Backward to Center position or (3>manual brake is operated, the vehicle is considered to brake. The brake light will be lit After 5 seconds, the light will switch off automatically.
Usage Condition	While (1) controller shut down (2) on power-saving mode, all functions closed.
Remarks	(1) Loop Load of Brake light: 24V/50W Max (2) With "short circuit" and "overload" protection

Turn Light and Parking Lights

ITEM	DESCRIPTIONS
(Control Mode) Left Turn Light	Press left-indicator button once, the left light and left indicator starts to flash, and warning tone sounds simultaneously; press button again to switch off the indicator/light and tone.
Right Turn Light	Press right-indicator button once, the right light and right indicator starts to flash, and warning tone sounds simultaneously; press button again to switch off the indicator/light and tone.

Automatic Turn Off	The direction lights and indicators will be turned off automatically while flashing for 30 seconds.
Hazard Lights	Press hazard indicator button once, the right/left lights and hazard indicator start to flash, warning tone acts as well; press button again will turn off above indicators and tone. To activate the parking lights while KEY ON, the lights would keep flashing even KEY OFF.
Determinant Condition	There is no priority between left / right lights or parking lights.
Usage Condition	While (1) controller shut down (2) in charging-mode, the function will be disabled.
Flicker Frequency	1 second, Duty 50%
Warning Tone Frequency	1 second, Duty 30%
Remarks	(1)Load circuit for left turn light: 24V/50W max (2)Load circuit for right turn light: 24V/50W max (3)With "short circuit" and "overload" protection (4)The volume of warning tones for left/right turn lights, parking lights could be adjusted.

2.Mode

2-1 Clock

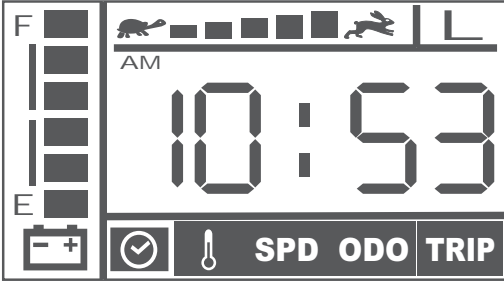
ITEM	DESCRIPTIONS
Timekeeping error per day	± 2 seconds
Initial Display	「 HH 」 「 MM 」 Mode : 「 AM 12:00 」
Time Format (12 hours- AM/PM)	<p>Press 「 Mode 」 button and switch to Clock mode.</p>  <p>Display range : AM12:00 ~ PM11:59</p> <p>HH display : The "0 of ten's digit is invisible from 10' clock to 90' clock.</p>

<p>Setup Mode (Time adjustment)</p>	<p>Press + together for 3 secs to enter setup mode.</p> <p>While 「HH」 is flashing, Press to increase digits and to decrease digits. Press 「Mode」 to enter「MM」setup mode when finished.</p> <p>While 「MM」 is flashing, Press to increase digits and to decrease digits. Press 「Mode」 to return 「HH」 setup mode when finished.</p> <p>Press () once to increase (decrease) one digit. The digits can increase (decrease) accumulating when press the buttons more than 2 secs. The display is cycling. It takes 2 secs to increase from 0 to 9 for each position.</p>
<p>Quit Setup Mode</p>	<p>The user could quit the setup mode with the following conditions.</p> <p>(1) Leave or buttons alone for 15secs.</p> <p>(2) Press any button of Parking light, Horn, Turn light or Headlight, the definitive settings will be stored and return to normal clock mode.</p>

2-2 Thermometer

ITEM	DESCRIPTIONS
<p>Operation Feature</p>	<p>Use thermistor (NTC) to detect the signal and transfers to related temperature.</p>
<p>Display Errors</p>	<p>± 2°C</p>
<p>Operational Mode of Thermometer</p>	<p>Press 「Mode」 button and switch to thermometer mode</p> <div data-bbox="668 1357 1177 1637" data-label="Image"> </div> <p>Display range : Centigrade -20~50°C or Fahrenheit -4~122°F</p>
<p>Setup Mode (Unit change)</p>	<p>Press + together for 3 secs to enter setup mode. While 「°C」 / (「°F」) is flashing, press or to switch to 「°F」 / (「°C」)</p>
<p>Quit Setup Mode</p>	<p>The user could quit the setup mode with the following conditions.</p> <p>(1) Leave or buttons alone for 15secs.</p> <p>(2) Press any button of Parking light, Horn, Turn signal or Headlight, the definitive settings will be stored and return to normal thermometer mode.</p>

2-3 Speedometer

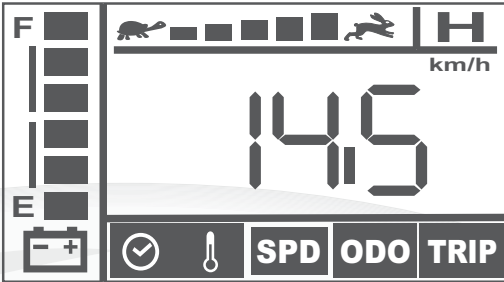
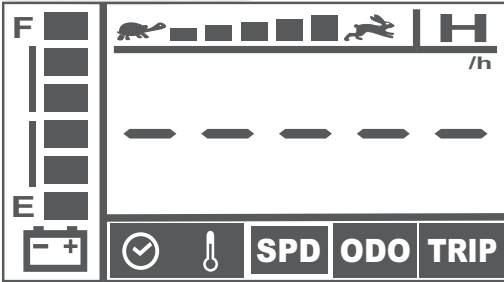
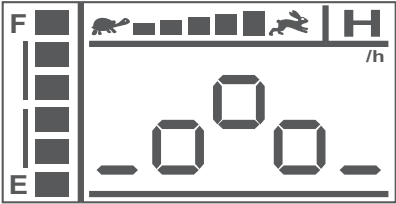
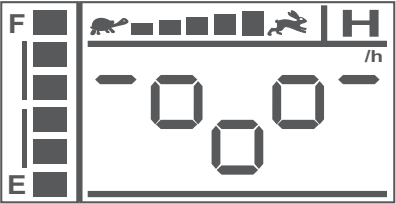
ITEM	DESCRIPTIONS
Operation Feature	Use optical coupler to detect the signal and transfer to related speed. Speed displays 60km/h while it's on 1500 rpm.
Display Errors	+15~20%
Display Range	0.0 ~ 30.0, display resolution: 0.5
Operational mode of speedometer	<p>Press 「 Mode 」 button and switch to speedometer</p>  <p>When "km/h" is displayed, speed will be indicated in km per hour.</p> <p>When "MPH" is displayed, speed will be indicated in miles per hour.</p> <p>When "/h" is displayed, the function of speedometer will be disable. (This display will be applied to the model that is not equipped with optical coupler) And the display will be replaced to WIP(accelerator) operation indicator as follows:</p> <p>Standby Indication</p>  <p>Forward Indication</p>  <p>Backward Indication</p> 
Setup Mode (Unit change)	Press 🐢 + 🐇 together for 3 secs to enter setup mode. While 「 km/h 」 / (「 MPH 」) is flashing, press 🐇 or 🐢 to switch to 「 MPH 」 / (「 km/h 」).

<p>Setup Mode (Unit change)</p>	<p>The user could quit the setup mode with the following conditions.</p> <p>(1) Leave 🐢 or 🐰 buttons alone for 15secs.</p> <p>(2) Press any button of Parking light, Horn, Turn light or Headlight, the definitive settings will be stored and return to normal speedometer mode.</p>
-------------------------------------	---

2-4 Odometer



ITEM	DESCRIPTIONS
Operation Feature	Use optical coupler to detect the signal and transfer to related distances.
Unit Switch	<p>When speedometer was set as 「km/h」, the odometer displays as kilometer.</p> <p>「mph」, the odometer displays as mile.</p> <p>「/h」, means the odometer is displaying as travel hours.</p>
ODO Mode	<p>Press 「Mode」 button and switch to ODO mode.</p> <div data-bbox="667 902 1177 1182" data-label="Image"> </div> <p>Display range : 0~99999 When the total distance goes to 99999km or 62149mile (99999 ÷ 1.609mile), the digits will be reset to zero "0".</p>

2-5 TRIP Mode

ITEM	DESCRIPTIONS
TRIP Mode	<p>Press 「Mode」 button and switch to TRIP mode.</p> <div data-bbox="667 1552 1177 1832" data-label="Image"> </div> <p>Display range: 0.0~999.9 When the distance goes to 999.9, the counter will stop.</p>
Reset Mode (Rest TRIP to Zero)	<p>Press 🐰 + 🐢 together for 3 secs to enter setup mode. While 「TRIP」 is flashing, press 「Mode」 for 3 secs to reset to zero "0.0"</p>

Quit Setup Mode	<p>The user could quit the setup mode with the following conditions.</p> <p>(1) Leave 「 Mode 」 button alone for 15secs.</p> <p>(2) Press any button of Parking light, Horn, Turn signal or Headlight, the definitive settings will be stored and return to normal TRIP mode.</p>
-----------------	--

3.Notice to Routine Maintenance for certain mileage

ITEM	DESCRIPTIONS
Display I for Routine Maintenance	<p>The initial mileage of routine maintenance is 5000km</p> <p>Display :</p> <p>When it reaches the mileage for routine maintenance, ODO symbol will start to flash for 1 minute.</p> <p>Time to display :</p> <ol style="list-style-type: none"> 1.when the ODO reaches the mileage for routine maintenance during driving 2.when the ODO reaches the mileage for routine maintenance during Key On  <p>PS.During flashing, the mobility vehicle could be drove normally and the control penal could be operated without any delay.</p>
Display II for Routine Maintenance	<p>After the routine maintenance is finished, the user could setup the mileage for next maintenance. (Count down setting)</p> <p>Setup steps:</p> <ol style="list-style-type: none"> 1.Press 「 Mode 」 button and switch to ODO mode 2.Key off to shut down the controller 3.Press 「 Mode 」 and 「 H/L 」 buttons together 4.Key on to start the controller 5.The display will enter setup mode in 2 secs, the mileage will be flashing. (as Note 1) 6.Press  or  button to adjust to the mileage for next maintenance (as Note 2) 7.After setup is finished, press any button of Parking light, Horn, Turn signal or Headlight, the definitive settings will be stored and return to normal working mode. 8.The display will quit to normal working mode while the user does not press or button in 10 secs.

Note 1 : Setup mode

The mileage counts down to 0km

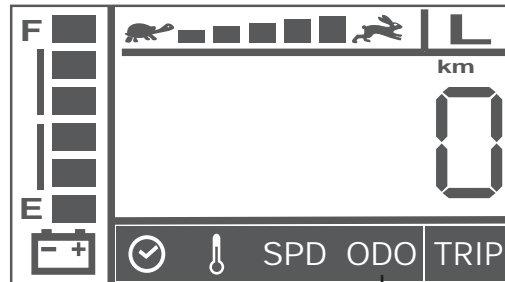

Flashing

The mileage does not count down to 0km.

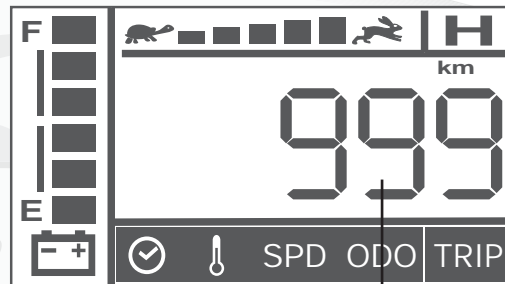

Flashing

Display II for Routine Maintenance



































Note 2

Press or button to adjust to the mileage for next maintenance.



















Press to increase the mileage :
 1000 2000 3000 4000 5000 OFF 1000.
 (displays in cycling)

Press to decrease the mileage :
 OFF 5000 4000 3000 2000 1000 OFF.
 (displays in cycling)

4. Digital High / Low Speed Control











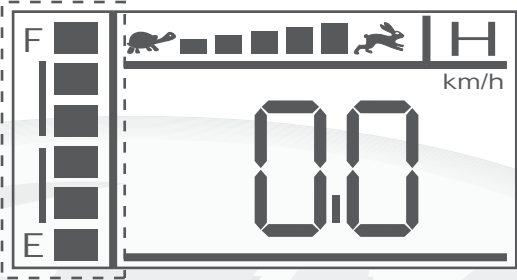



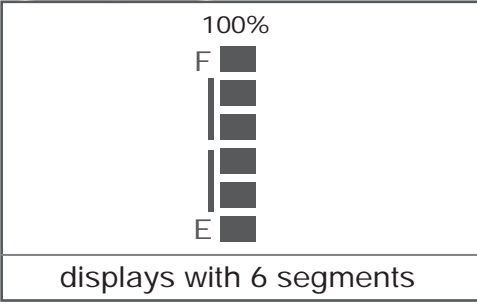

ITEM	DESCRIPTIONS																		
Operation Feature	Press 「H/L Speed」 button to switch High/Low speed Press  or  to fine tune in 5 speeds																		
Control Mode	Press 「H/L Speed」 button once, the High/Low Speed Indicator (H) will light on. Press again, the indicator will light off. Press  button to increase the speed Press  button to decrease the speed <table border="1" data-bbox="638 660 1204 974"> <thead> <tr> <th>Speed Display</th> <th>H % (Max)</th> <th>L % (Max)</th> </tr> </thead> <tbody> <tr> <td> </td> <td>20</td> <td>10</td> </tr> <tr> <td> </td> <td>40</td> <td>20</td> </tr> <tr> <td> </td> <td>60</td> <td>30</td> </tr> <tr> <td> </td> <td>80</td> <td>40</td> </tr> <tr> <td> </td> <td>100</td> <td>50</td> </tr> </tbody> </table>	Speed Display	H % (Max)	L % (Max)	 	20	10	 	40	20	 	60	30	 	80	40	 	100	50
Speed Display	H % (Max)	L % (Max)																	
 	20	10																	
 	40	20																	
 	60	30																	
 	80	40																	
 	100	50																	
Usage Condition	While (1) controller shut down (2) in charging-mode, the function will be disabled.																		

5. Power Indicator





ITEM	DESCRIPTIONS																								
Discharge Capacity	<table border="1" data-bbox="670 1288 1181 1601"> <thead> <tr> <th>Capacity (%)</th> <th>Status Display</th> </tr> </thead> <tbody> <tr> <td>40%</td> <td>55%</td> <td>70%</td> <td>85%</td> <td>100%</td> </tr> <tr> <td>F</td> <td>F</td> <td>F</td> <td>F</td> <td>F</td> </tr> <tr> <td></td> <td></td> <td></td> <td></td> <td></td> </tr> <tr> <td>E</td> <td>E</td> <td>E</td> <td>E</td> <td>E</td> </tr> </tbody> </table> <table border="1" data-bbox="670 1624 1181 1937"> <tbody> <tr> <td> <p>30%</p> <p>F</p>  <p>E</p> <p>← Flashing</p> </td> </tr> <tr> <td>(Status indicator LED will be flashing)</td> </tr> </tbody> </table>	Capacity (%)	Status Display	40%	55%	70%	85%	100%	F	F	F	F	F						E	E	E	E	E	<p>30%</p> <p>F</p>  <p>E</p> <p>← Flashing</p>	(Status indicator LED will be flashing)
Capacity (%)	Status Display																								
40%	55%	70%	85%	100%																					
F	F	F	F	F																					
																									
E	E	E	E	E																					
<p>30%</p> <p>F</p>  <p>E</p> <p>← Flashing</p>																									
(Status indicator LED will be flashing)																									
Operation Characters	The segments will decrease only, won't increase.																								

Low Voltage Warning Tone	When the battery capacity is lower than 30%, the warning tone will be beeped once with "BiBi - BiBi -- BiBi" 3 short double beeps.
Flicker Frequency	Once per two seconds
Usage Condition	While (1) controller shut down (2) in charging-mode, the function will be disabled.

Charge Status

ITEM	DESCRIPTIONS												
Charge Status	<p>The charging status displays with segments cycling, increasing only, won't decrease.</p> 												
Charging Indicating	<table border="1" style="width: 100%; text-align: center;"> <thead> <tr> <th>Capacity(%)</th> <th>Display status of segments</th> </tr> </thead> <tbody> <tr> <td>40%</td> <td>  </td> </tr> <tr> <td>55%</td> <td>  </td> </tr> <tr> <td>70%</td> <td>  </td> </tr> <tr> <td>80%</td> <td>  </td> </tr> <tr> <td>90%</td> <td>  </td> </tr> </tbody> </table> <div style="text-align: center;"> <p>100%</p>  <p>displays with 6 segments</p> </div>	Capacity(%)	Display status of segments	40%		55%		70%		80%		90%	
Capacity(%)	Display status of segments												
40%													
55%													
70%													
80%													
90%													
Increasing ratio	0.5 second												
Operation Feature	<p>(1) The segments will increase only, won't decrease. (2) Take PIN3 (CH3) of charger as determinant signal. No matter of KEY ON or KEY OFF, the charging mode will be activated once CH3 is connected to Ground(L) (3) The LCD back light will be ON while any button is pressed. It will light off automatically in 5 seconds if no button has been pressed.</p>												
Remarks	Displayed segments are for reference only. Please refer to indicator of charger for more accurate charging status.												













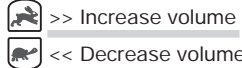













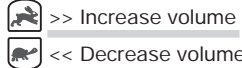













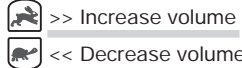

6. Malfunction Messages

ITEM	DESCRIPTIONS																														
Operation Feature	Take the connector pin (KEY) of controller as determinant signal, then converts it into digital codes.																														
Usage Condition	When the controller sends out an error message,  (LED) starts flashing to wait for confirming and display the "Error message code" as follows. <table border="1" style="margin: 10px auto;"> <thead> <tr> <th> flashing</th> <th>LCD code</th> <th>Status</th> </tr> </thead> <tbody> <tr> <td>1</td> <td>Err 1</td> <td>Battery needs charging soon.</td> </tr> <tr> <td>2</td> <td>Err 2</td> <td>Low voltage, needs charging now</td> </tr> <tr> <td>3</td> <td>Err 3</td> <td>Over voltage</td> </tr> <tr> <td>4</td> <td>Err 4</td> <td>Over current</td> </tr> <tr> <td>5</td> <td>Err 5</td> <td>Park Brake is lost or faulted</td> </tr> <tr> <td>6</td> <td>Err 6</td> <td>Accelerator not aligns in center</td> </tr> <tr> <td>7</td> <td>Err 7</td> <td>Accelerator is broken or faulted</td> </tr> <tr> <td>8</td> <td>Err 8</td> <td>Motor is broken or faulted</td> </tr> <tr> <td>9</td> <td>Err 9</td> <td>Others</td> </tr> </tbody> </table>	 flashing	LCD code	Status	1	Err 1	Battery needs charging soon.	2	Err 2	Low voltage, needs charging now	3	Err 3	Over voltage	4	Err 4	Over current	5	Err 5	Park Brake is lost or faulted	6	Err 6	Accelerator not aligns in center	7	Err 7	Accelerator is broken or faulted	8	Err 8	Motor is broken or faulted	9	Err 9	Others
 flashing	LCD code	Status																													
1	Err 1	Battery needs charging soon.																													
2	Err 2	Low voltage, needs charging now																													
3	Err 3	Over voltage																													
4	Err 4	Over current																													
5	Err 5	Park Brake is lost or faulted																													
6	Err 6	Accelerator not aligns in center																													
7	Err 7	Accelerator is broken or faulted																													
8	Err 8	Motor is broken or faulted																													
9	Err 9	Others																													

7. Key On Display

ITEM	DESCRIPTIONS
Initial Status	When scooter power on, the backlight and all LCD segments will be tuned on for 3 seconds, then switch to the default working mode automatically.

8. Warning Tone Setup

ITEM	DESCRIPTIONS																														
Operation Feature	The volume of warning tones of Parking light, Reverse, Horn, Low voltage and Turn signal could be adjusted or turned off. (except you cannot turn off the Horn)																														
	<table border="1" style="width: 100%; border-collapse: collapse;"> <thead> <tr> <th>Function</th> <th>Buttons (A+B)</th> <th>Status</th> <th>Initial</th> <th>Volume</th> </tr> </thead> <tbody> <tr> <td>Parking Light Warning Tone</td> <td> + </td> <td>SE7 1</td> <td>Less Loud</td> <td>  >> Increase volume << Decrease volume </td> </tr> <tr> <td>Reverse Warning Tone</td> <td> + </td> <td>SE7 2</td> <td>Less Loud</td> <td>  Volume </td> </tr> <tr> <td>Volume of Horn</td> <td> + </td> <td>SE7 3</td> <td>Loud</td> <td>  Loud Less Loud </td> </tr> <tr> <td>Low Voltage Warning Tone</td> <td> + </td> <td>SE7 4</td> <td>Less Loud</td> <td>  Normal Quiet </td> </tr> <tr> <td>Turn Light Warning Tone</td> <td> + </td> <td>SE7 5</td> <td>Less Loud</td> <td>  Silent </td> </tr> </tbody> </table>	Function	Buttons (A+B)	Status	Initial	Volume	Parking Light Warning Tone	 + 	SE7 1	Less Loud	 >> Increase volume << Decrease volume	Reverse Warning Tone	 + 	SE7 2	Less Loud	 Volume	Volume of Horn	 + 	SE7 3	Loud	 Loud Less Loud	Low Voltage Warning Tone	 + 	SE7 4	Less Loud	 Normal Quiet	Turn Light Warning Tone	 + 	SE7 5	Less Loud	 Silent
Function	Buttons (A+B)	Status	Initial	Volume																											
Parking Light Warning Tone	 + 	SE7 1	Less Loud	 >> Increase volume << Decrease volume																											
Reverse Warning Tone	 + 	SE7 2	Less Loud	 Volume																											
Volume of Horn	 + 	SE7 3	Loud	 Loud Less Loud																											
Low Voltage Warning Tone	 + 	SE7 4	Less Loud	 Normal Quiet																											
Turn Light Warning Tone	 + 	SE7 5	Less Loud	 Silent																											

CAUTION

1. Obstacle Climbing :

Your scooter can climb obstacles and kerbs of up to 6cm in height. Never attempt to overcome an obstacle when on an uphill or downhill gradient! Always approach obstacles straight on! Ensure that the front wheels and rear wheels move over the obstacle in one stroke, do not stop halfway!

2. The maximum gap the scooter can drive over is 22cm,

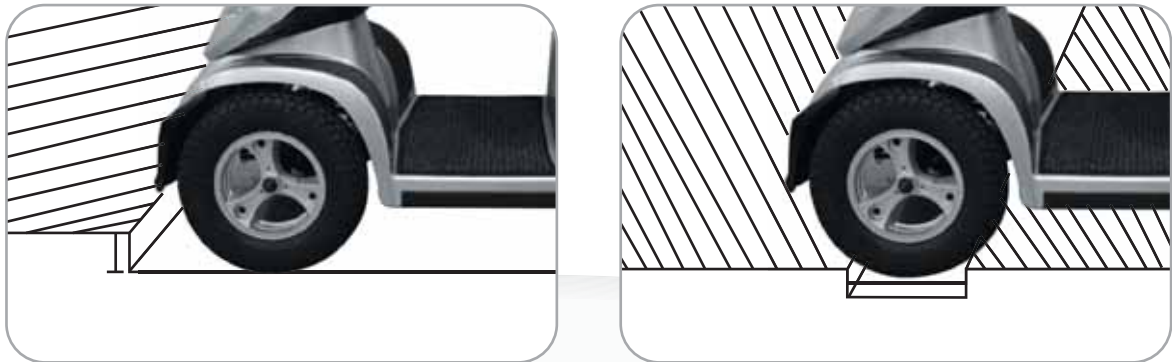

In unlikely event of a panel display error, you need to re-set the display system by cycling the on/off main switch. The display circuitry is independent of the motor control system. A display console error does not affect scooter speed control.

OTHER

1. Charge the batteries after each trip, if the scooter is not used for some time batteries must be charged at least once a month. make sure that batteries are fully charged, and on returning, charge them again before using scooter.
2. Check the battery gauge before driving to prevent power depletion.
3. Do not disassemble battery and open sealed parts by yourself to prevent electric shock and burns from acid leakage.
4. Adjust speed to a slow speed when starting off to prevent sudden acceleration.
5. Never attempt to drive downhill backwards.
6. Try not to drive scooter at night or in rain or bad weather.
7. If storing your scooter for a long time (1 month or more), make sure that battery are fully charged, then disconnect the two batteries plugs (W), and the store scooter in a dry location.

TECHNICAL SPECIFICATIONS

Overall Length	1600 mm / 63"
Overall Width	720 mm / 28.4"
Overall Height	1280 mm / 50"
Wheels : Front	380 mm / 15"
Wheels : Rear	380 mm / 15"
Weight w/ Batteries	178 kg / 392 lbs
Max. Speed	15 kmph / 9 mph
Weight Capacity	226 kg / 498 lbs
Ground Clearance	110mm / 4.3"
Grade Climbable	9 degree
Curb Climbing	60 mm / 2.4"
Turning Radius	1860 mm / 73.2"
Suspension	Front & Rear
Brake	Manual hand Break & Electro-Mechanical
Seat Type	Sliding and Swivel Reclining Captain W/Headrest
Seat Width	559 mm / 22"
Motor Size	800W, 4300 r.p.m.
Battery Size	(2) 12V. 100Ah
Battery Weight	68.5 kg / 151 lbs
Travel Range	50 km / 31 Miles
Battery Charger	15A Off Board
Electronics	On / Off Key Switch, Battery Level Indicator, Speed Control Knob

*Subject to change without notice.